



**DB3-4-5 Series Centrifugal Pumps**  
**Assembly, Installation and Operation Manual**





**FINISH THOMPSON INC.**

921 Greengarden Road • Erie, PA 16501-1591 U.S.A.  
Ph 814-455-4478 • Fax 814-455-8518  
Email [fti@finishthompson.com](mailto:fti@finishthompson.com) • [www.finishthompson.com](http://www.finishthompson.com)

**EU Declaration of Conformity**



Finish Thompson Inc. hereby declares that the following machine(s) fully comply with the applicable health and safety requirements as specified by the EC Directives listed. The product may not be taken into service until it has been established that the drive motor for the centrifugal pump complies with the provisions of all relevant EC Directives. The complete product complies with the provisions of the EC Directive on machinery safety provided motors carry CE marking.

This declaration is valid provided that the devices are fully assembled and no modifications are made to these devices.

**Type of Device:**  
Centrifugal Pumps

**Models:**

AC/AK/AV - 400/500/600/800	DB-3/4/5/5.5/6/6H/7/ 8/9/10/11/15/22	GP-11/22/32
KC-3/4/5/5.5/6/6H/8/10/11/22/32 SP-10/11/15	MSKC UC-1516/1518/326	MSVKC VKC-5.5/6/6H/7/8/10

**EC Directives:**

Machinery Safety (2006/42/EC)

Applied Harmonized Standards:

EN ISO 12100 Part 1  
EN ISO 12100 Part 2  
EN 809

**Manufacturer:**

Finish Thompson Inc.  
921 Greengarden Road  
Erie, Pennsylvania 16501-1591 U.S.A

Signed,

\_\_\_\_\_  
President

April 19, 2010

Person(s) Authorized to Compile Technical File: Michael Smith Engineers Limited  
Oaks Road, Woking, Surrey  
GU21 6PH, UK  
Telephone: 01483 771871

# Table of Contents

Important Information - Read Me First . . . . .	1
Chemical Reaction Disclaimer	
Safety Precautions	
Installation/Operation Precautions . . . . .	2
Section I - Assembly . . . . .	3
Section II - Installation . . . . .	4-5
Mounting	
Piping	
Motor/Electrical	
Section III - Start-up and Operation . . . . .	5
Section IV - Maintenance . . . . .	5
Section V - Disassembly . . . . .	5-7
Recommended Maintenance Schedule	
Outer Drive Replacement	
Thrust Ring Replacement	
Bushing Replacement	
Section VI - Reassembly . . . . .	7
Section VII - Troubleshooting . . . . .	8
Section VIII - Warranty . . . . .	8
Part Number Explanation . . . . .	9
Spare Parts Drawing . . . . .	10
Spare Parts List . . . . .	11

## FTI Contacts:

Tech Service: PH 800-888-3743; Email [techservice@finishthompson.com](mailto:techservice@finishthompson.com)

Order Fax: 814-459-3460 or 814-455-8518

Sales: 1-814-455-4478; Toll Free 1-800-934-9384 (U.S. & Canada)

# IMPORTANT INFORMATION - READ ME FIRST!

## Model Number and Serial Number

Record the model number and serial number below for future reference. This is important information when ordering replacement parts or when technical assistance is required. The numbers are found on a label located on the motor adapter.

MODEL NUMBER = \_\_\_\_\_

SERIAL NUMBER = \_\_\_\_\_

## Chemical Reaction Disclaimer

The user must exercise primary responsibility in selecting the product's materials of construction, which are compatible with the fluid(s) that come(s) in contact with the product. The user may consult Finish Thompson, Inc. (manufacturer) and a manufacturer's representative/distributor agent to seek a recommendation of the product's material of construction that offers the optimum available chemical compatibility.

However neither manufacturer nor agent shall be liable for product damage or failure, injuries, or any other damage or loss arising out of a reaction, interaction or any chemical effect that occurs between the materials of the product's construction and fluids that come into contact with the product's components.

## Safety Precautions

**⚠ WARNING:** READ THIS MANUAL COMPLETELY BEFORE INSTALLING AND OPERATING THIS UNIT. FAILURE TO FOLLOW THESE PRECAUTIONS CAN RESULT IN SERIOUS INJURY OR DEATH.

**⚠ WARNING:** Magnetic field hazard: This pump contains powerful magnets. Exposed magnets (pump not connected to motor) produce powerful magnetic fields. Individuals with cardiac pacemakers, implanted defibrillators, other electronic medical devices, metallic prosthetic heart valves, internal wound clips (from surgery), metallic prosthetic devices or sickle cell anemia must not handle or be in the proximity of the magnets contained inside the pump. Consult a health care provider for specific recommendations before working with this pump.

**⚠ WARNING:** Magnetic force hazard. This pump should only be disassembled and assembled using the recommended procedures. The magnetic attraction is powerful enough to rapidly pull the motor end and the wet end together. Do not place fingers between the mating surfaces of the motor and wet ends to avoid injuries. Keep the drive magnet and impeller assembly away from metal chips or particles, items with magnetic stripes like credit cards and magnetic computer media such as floppy discs and hard drives.

**⚠ WARNING:** Hot surfaces. This pump is capable of handling liquids with temperatures as high as 220° F (104° C). This may cause the outer areas of the pump to become hot as well and could cause burns.

**⚠ WARNING:** Rotating Parts. This pump has components that rotate while in operation. Follow local safety standards for locking out the motor from the power supply during maintenance or service.

**⚠ WARNING:** Chemical Hazard. This pump is used for transferring many types of potentially dangerous chemicals. Always wear protective clothing, eye protection and follow standard safety procedures when handling corrosive or personally harmful materials. Proper procedures should be followed for draining and decontaminating the pump before disassembly and inspection of the pump. There may be small quantities of chemicals present during inspection.

**⚠ WARNING:** The pump and associated components are heavy. Failure to properly support the pump during lifting and movement could result in serious injury or damage to the pump and components.

**⚠ WARNING:** Never run pump at less than minimum flow or with the discharge valve closed. This could lead to pump failure.

## Installation/Operation Precautions

**⚠ CAUTION:** This pump should never be operated without liquid in the casing. It is recommended that run dry protection be used. Optional electronic power monitors are available to help protect against run dry. If the pump has a PTFE or ceramic bushing, IT CANNOT BE RUN DRY WITHOUT CAUSING DAMAGE TO THE PUMP. However, the pump can operate without liquid in the casing if the pump has a carbon bushing. The exact length of time the pump can operate dry with a carbon bushing varies with operating conditions and the environment.

**⚠ CAUTION:** Never start or operate with a closed suction valve. Never operate with a closed discharge valve.

**⚠ CAUTION:** Always provide adequate NPSHa (net positive suction head available). It is recommended to provide at least 2 feet (61 cm) above the NPSHr (net positive suction head required).

### DB3, 4 & 5 Capabilities

**Maximum Working Pressure:** 60 psi (4.1 bar)

**Maximum Viscosity:** 50 cP

**Maximum Temperature:** Polypropylene: 180° F (82° C); PVDF: 220° F (104° C)

NOTE: Maximum temperature is application dependent. Consult a chemical resistance guide or the chemical manufacturer for chemical compatibility and temperature limits.

**Solids:** Maximum particle size is 100 microns for slurries and 1/64" (.4 mm) for infrequent particles. Maximum hardness is 80 HS. Maximum concentration is 10% by weight. Pumping solids may lead to increased wear.

**Minimum Allowable Flow Rate:** Do not allow the flow rate to drop below the minimum flow rate listed in the chart below.

3450 rpm	2900 rpm
.25 gpm (.95 lpm)	.95 lpm (.25 gpm)

**Maximum Allowable Motor Power:** Do not exceed the maximum power rating for the pump coupling.

Standard coupling for the DB3/4/5 is 4-pole. Maximum motor power is 1/4 horsepower (.18 kW).

### Unpacking and Inspection

Unpack the pump and examine for any signs of shipping damage. If damage is detected, save the packaging and notify the carrier immediately.

## Section I - Assembly

### Pumps with Motors

Proceed to Installation Section

### Pumps Without Motors

Tools Required: Metric socket set, 7 mm socket (63 frame), 2.5 mm (56 frame) & 3 mm Allen wrenches & Phillips-head screwdriver.

1. Remove the pump, drive magnet assembly and hardware package from the carton.

**⚠ CAUTION:** Keep away from metallic particles, tools and electronics. Drive magnets MUST be free of metal chips.

**⚠ WARNING:** Keep the drive magnet away from the open end of the motor adapter and barrier. Strong magnetic attraction could allow the drive hub to enter the motor adapter resulting in injury or damage.

2. Place motor on the fan end. See figure 1.



Figure 1

NOTE: The DB3, 4 & 5 pumps mount to either IEC 56 or 63 B14 frame motors depending on which motor adapter is ordered. The motor adapter flange (item 6) can be used for either frame depending on which side is used. See stamped identification on the flange. See figure 2.



Figure 2

3. Install the motor adapter flange (item 6) on the motor face using motor adapter flange bolts (item 12).

NOTE: Apply anti-seize compound on the threads of the bolts. Hand tighten bolts being careful not to over tighten. See figure 3.

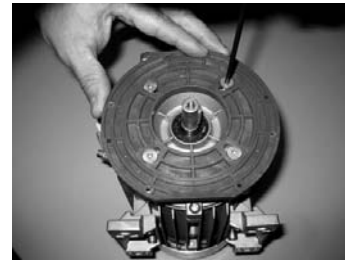

Figure 3

4. Make sure the motor shaft is clean and free of burrs. Coat the motor shaft with anti-seize compound. If not installed insert key supplied with motor into keyway on motor shaft.

NOTE: The outer drive is precision machined and has a bore tolerance of +0.001/-0 inch. It may be necessary to tap the drive on with a soft mallet.

5. Slide the outer drive magnet assembly (item 5) onto the motor shaft until the motor shaft contacts the snap ring in the bore of the drive. Turn the drive by hand to make sure it rotates freely. See figures 4 & 5.



Figure 4



Figure 5

**⚠ WARNING:** Be careful, magnets will try to attract tools.

6. Secure the drive on the motor shaft using bolt, lock washer and flat washer (items 9, 10, 11). Coat the bolt threads with anti-seize compound. Thread the bolt into the end of the motor shaft (while holding the outer drive to prevent it from turning). See figure 6.

Tighten the bolt using the 2.5 mm allen wrench (56 frame) or 7mm socket (63 frame) to the following torque rating:

- 56 frame (M3) = 8 in-lb (.9 N-m)
- 63 frame (M4) = 15 in-lb (1.7 N-m)

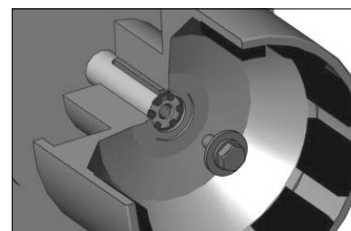

Figure 6

7. Install the pump end on the motor/drive magnet assembly. Carefully slide the pump onto the drive magnet assembly. See figure 7.
8. Secure the pump to the motor adapter flange (item 6) with (4) motor adapter screws (item 8). Hand tighten screws being careful not to over tighten. See figure 8.



Figure 7

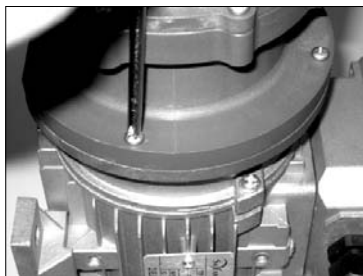

Figure 8

9. Rotate the motor fan or turn the impeller to ensure that there is no binding in the pump.
10. Proceed to Installation Section.

## Section II – Installation

### Mounting

Motor feet should be securely fastened to a solid foundation.

#### Instructions for horizontal discharge installation:

Note: The pump ships from the factory so the discharge will be in a vertical orientation. These instructions allow a horizontal discharge.

1. Place the pump & motor in an upright position on the fan end of the motor. Remove (8) housing screws (item 7). Pull the housing away from the motor adapter / barrier (item 4) and remove the o-ring (item 2). Reinstall the housing in the 3:00 position looking from the pump side. Note: O-ring will be lubricated from the factory and should not require additional lubrication. See figure 9.
2. Reinstall the o-ring onto the housing (item 1). If o-ring will not stay in place it may be necessary to roll the o-ring under when installing it on the housing. See figure 10.



Figure 9



Figure 10

3. Align the holes in the housing with the motor adapter / barrier. Push the housing with o-ring in place straight down to seat the o-ring. Hold the housing in place and reinstall the (8) housing screws (items 7, 7A) in a star like pattern using

the Phillips-head screwdriver. Hand tighten screws being careful not to over tighten. See figures 11 & 12.

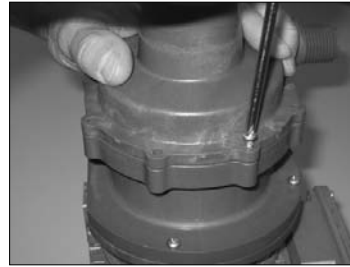

Figure 11

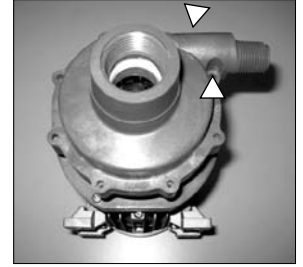

Figure 12

NOTE: Install two long screws (item 7A) inserting one on either side of the discharge nozzle. See figure 12.

### Piping

**CAUTION:** The NPSH available must be greater than the NPSH required. Filters, strainers and any other fittings in the suction line will lower the NPSH available and should be calculated into the application.

- Install the pump as close to the suction source as possible.
- Support the piping independently near the pump to eliminate any strain on the pump casing. In addition, the piping should be aligned to avoid placing stress on the pump casing.
- The suction side of the pump should be as straight and short as possible to minimize pipe friction.
- Keep bends and valves at least ten pipe diameters away from the suction and discharge.
- The suction line should be at least as large as the suction inlet port or one pipe size larger so that it does not affect the NPSHa. Do not reduce the suction line size.
- The suction line should not have any high spots. This can create air pockets. The suction piping should be level or slope slightly upward to the pump.
- A check valve and control valve (if used) should be installed on the discharge line. The control valve is used for regulating flow. An isolation valves on both the suction and discharge is used to make the pump accessible for maintenance. The check valve helps protect the pump against damage from water hammer. This is particularly important when the static discharge head is high.
- If flexible hose is preferred, use a reinforced hose rated for the proper temperature, pressure and is chemically resistant against the fluid being pumped.
- The suction valve must be completely open to avoid restricting the suction flow.
- It is advisable to install a flush system in the piping to allow the pump to be flushed before the pump is removed from service.

## Motor/Electrical

Install the motor according to NEC requirements and local electrical codes. The motor should have an overload protection circuit.

Wire the motor for counter-clockwise rotation when facing the fan end of the motor.

**⚠ CAUTION:** Do not operate the pump to check rotation until the pump is full of liquid.

Check all electrical connections with the wiring diagram on the motor. Make sure the voltage, frequency, phase and amp draw comply with the supply circuit.

If motor is supplied by Finish Thompson please use the following wiring diagram:

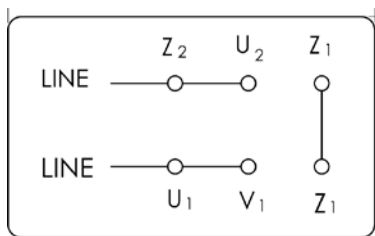

If utilized, verify that the power monitor has been properly installed according to the manufacturers instructions.

To verify correct rotation of the motor:

1. Install the pump into the system.
2. Fully open the suction and discharge valves.
3. Allow fluid to flow into the pump. Do not allow the pump to run dry. PTFE or ceramic bushings can't be run dry without damage to pump components.
4. Jog the motor (allow it to run for 1-2 seconds) and observe the rotation of the motor fan. Refer to the directional arrow molded into the housing.

NOTE: A pump running backwards will pump but at a greatly reduced flow and pressure.

## Section III - Start- up and Operation

1. This pump must be filled from a flooded suction tank (gravity) or primed with liquid from an outside source. DB Series pumps are not self-priming.
2. Open the inlet (suction) and discharge valves completely and allow the pump to fill with liquid.
3. Close the discharge valve.
4. Turn the pump on. Slowly open the discharge valve. Adjust the flow rate and pressure by regulating the discharge valve. Do not attempt to adjust the flow with the suction valve.

5. Use of a power monitor is strongly recommended for pumps with PTFE bushings. The power monitor will stop the pump and help prevent damage if the pump should run dry.

## Shutdown

Use the following procedure to shutdown the pump.

1. Slowly close the discharge valve.
2. Turn off the motor.
3. Close the suction valve.

## Flush Systems

**⚠ CAUTION:** Some fluids react with water; use compatible flushing fluid.

1. Turn off the pump.
2. Completely close the suction and discharge valves
3. Connect flushing fluid supply to flush inlet valve.
4. Connect flushing fluid drain to flush drain valve.
5. Open flushing inlet and outlet valves. Flush system until the pump is clean.

## Section IV - Maintenance

### Recommended Maintenance Schedule

The recommended maintenance schedule depends upon the nature of the fluid being pumped and the specific application. If the pump is used on a clean fluid, it is recommended that the pump be removed from service and examined after six months of operation or after 2,000 hours of operation. If the pump is used on fluids with solids, high temperatures, or in other conditions that could cause accelerated wear, then this initial examination should be sooner.

After the initial examination of the internal components and wear items are measured, a specific maintenance schedule can be determined. For best results, it is recommended that the pump be removed from service annually for examination.

## Section V - Disassembly

**⚠ WARNING:** Rotating Parts. This pump has components that rotate while in operation. Follow local safety standards for locking out the motor from the power supply during maintenance or service.

**⚠ WARNING:** Chemical Hazard. This pump is used for transferring many types of potentially dangerous chemicals. Always wear protective clothing, eye protection and follow standard safety procedures when handling corrosive or personally harmful materials. Proper procedures should be followed for draining and decontaminating the pump before disassembly and inspection of the pump. There may be small quantities of chemicals present during inspection.

**⚠ WARNING:** Magnetic force hazard. This pump should only be disassembled and assembled using the recommended procedures. The magnetic attraction is powerful enough to rapidly pull the motor end and the wet end together. To avoid injuries, do not place fingers between the mating surfaces of the motor and wet end. Keep the drive magnet and impeller assembly away from metal chips or particles.

1. Stop the pump, lock out the motor starter, close all the valves that are connected to the pump, and drain/decontaminate the pump.

**⚠ WARNING:** The pump must be thoroughly flushed of any hazardous materials and all internal pressure relieved prior to opening the pump. Allow the pump to reach ambient temperatures prior to performing maintenance.

2. Place the pump & motor vertically on the motor fan end on a work bench. Remove the (4) screws (item 8) securing the pump to the motor adapter / barrier (item 4). See figure 13.



Figure 13

3. Firmly grab the pump and pull straight up to disengage the motor and pump. See figure 14.
4. Place pump on bench with housing facing up. Remove (8) housing screws (item 7). See figure 15.



Figure 14



Figure 15

5. Pull housing (item 1) straight up to remove. Inspect housing for signs of wear or damage. Look for signs of rubbing or cracked thrust ring. See figure 16.
6. Remove impeller assembly (item 3). See figure 17. Inspect impeller and drive for signs of wear or damage. Look for signs of rubbing, damage and wear. Check the impeller thrust ring and bushing for wear.



Figure 16



Figure 17

NOTE: Replace the thrust washer and bushing if wear exceeds dimensions in figure 18.

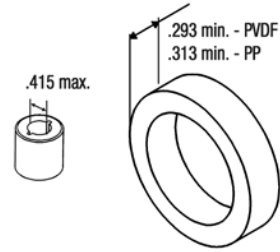

Figure 18

7. Remove the o-ring (item 2) and look for chemical attack, swelling, brittleness, cuts, etc. See figure 19.
8. Inspect the motor adapter / barrier (item 4). Inspect the inside and outside for signs of rubbing or damage. See figure 20.



Figure 19



Figure 20

9. Visually inspect the outer drive (item 5) for rubbing, damage, corrosion or loose magnets. See figure 21.



Figure 21

## Outer Drive Replacement

1. Remove the bolt, lock washer and flat washer (items 9,10 & 11) from the center of the drive. Hold the drive with your hand to prevent it from turning. See figure 22.

**⚠ WARNING:** Be careful, tools may be attracted to the magnets.

2. Remove the drive magnet from the motor shaft by gently pushing down on 2 pry bars or large flat head screwdrivers from the bottom of the drive. See figure 23.



Figure 22



Figure 23

- To reinstall the original drive or a new drive, follow the instructions from Section I – Assembly, Pumps without Motors, Steps 4 - 6.

### Thrust Ring Replacement

- Thrust ring (item 3A) is held in-place with a press fit. Using fingers, pliers or flat head screwdriver pry ring up and out of the holder. See figure 24.
- To reinstall simply press the thrust ring into the impeller by hand. See figure 25.



Figure 24



Figure 25

### Bushing Replacement

To remove the bushing, place the impeller assembly in an arbor press. Insert a 1/2" (12.7mm) diameter plastic or wood dowel through the eye of the impeller and press the bushing out. See figure 26.

To replace the bushing (item 3B), place the top of the impeller on an arbor press with the thrust ring face down. Insert the front of the bushing into the center of the impeller assembly & press into place using a 3/4" (19 mm) diameter plastic or wood dowel until the bushing reaches the shoulder molded into the inner drive. See figures 27, 28, 29 & 30.



Figure 26



Figure 27



Figure 28



Figure 29



Figure 30

### Section VI - Reassembly

- Place impeller assembly (item 3) into the motor adapter / barrier (item 4). See figure 31.
- Install o-ring (item 2) onto housing (item 1). Lubricate the o-ring with P80 or a compatible lubricant. If o-ring will not stay in place it may be necessary to roll the o-ring under when installing it on the housing. See figure 32.



Figure 31

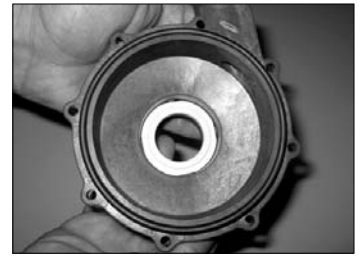

Figure 32

- NOTE: With the discharge port oriented in either a vertical (12:00) or horizontal (3:00) position, align the holes of the housing with the motor adapter / barrier. The flat side of the motor adapter / barrier aligns with the motor feet or bottom of the pump. See figures 33 & 34. See note on page 4, step 3 of Mounting.

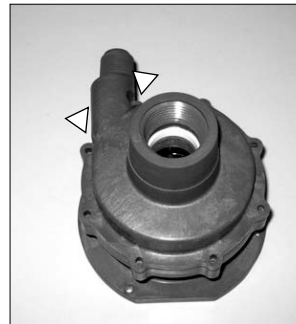

Figure 33  
Vertical Discharge



Figure 34  
Horizontal Discharge

NOTE: Install two long screws (item 7A) inserting one on either side of the discharge nozzle.

- Push the housing with o-ring in place straight down to seat the o-ring. Hold the housing in place & reinstall the (8) housing screws (item 7) in a star like pattern using the phillips head screw driver. Hand tighten screws being careful not to over tighten. See figure 35.



Figure 35

- To complete the reassembly go to Section I – Assembly, Pumps without Motors, Steps 4 - 10.

## Section VII - Troubleshooting

### General Notes:

- Do not pump liquids containing ferrous metal fines.
- If magnets decouple, stop pump immediately. Operating the pump with the magnets decoupled will eventually weaken the magnets.
- Do not use mismatched drive magnet assemblies (different number of magnets on inner and outer drive magnet assemblies).
- Phone FTI's Technical Service Department, **1-800-888-3743**, or e-mail, [techservice@finishthompson.com](mailto:techservice@finishthompson.com), if you have any questions regarding product operation or repair.

### No or Insufficient Discharge

- Air leaks in suction piping
- Pump not primed
- System head higher than anticipated
- Closed valve
- Viscosity or specific gravity too high
- Motor too large for magnet coupling rating (magnets uncoupled)
- Suction lift too high or insufficient NPSH
- Clogged suction line or impeller vanes
- Motor rotation incorrect (correct rotation when viewed from the fan end is counter clockwise)

### Insufficient Pressure

- Air or gas in liquid
- Impeller diameter too small
- System head lower than anticipated
- Motor speed insufficient or motor rotation incorrect (correct rotation when viewed from the fan end is counter clockwise)

### Loss of Prime

- Leak in suction piping
- Foot valve or suction opening not submerged enough
- Foot valve too small or leaking
- Air or gas in liquid
- Foreign matter in impeller
- Suction lift too high or insufficient NPSHa

### Excessive Power Consumption

- Head lower than rating
- Excessive flow
- Specific gravity or viscosity too high

### Vibration/Noise

- Loose magnet
- Drive magnet rubbing
- Pump cavitating from improper suction or feed
- Motor or piping not properly secured
- Foreign object in impeller

## Section VIII - Warranty

Finish Thompson, Inc (manufacturer) warrants this pump product to be free of defects in materials and workmanship for a period of **five years** from date of purchase by original purchaser. If a warranted defect, which is determined by manufacturer's inspection, occurs within this period, it will be repaired or replaced at the manufacturer's option, provided (1) the product is submitted with proof of purchase date and (2) transportation charges are prepaid to the manufacturer. Liability under this warranty is expressly limited to repairing or replacing the product or parts thereof and is in lieu of any other warranties, either expressed or implied. This warranty does not apply to normal wear of the product or components. This warranty does not apply to products or parts broken due to, in whole or in part, accident, overload, abuse, chemical attack, tampering, or alteration. The warranty does not apply to any other equipment used or purchased in combination with this product. The manufacturer accepts no responsibility for product damage or personal injuries sustained when the product is modified in any way. If this warranty does not apply, the purchaser shall bear all cost for labor, material and transportation.

Manufacturer shall not be liable for incidental or consequential damages including, but not limited to, process down time, transportation costs, costs associated with replacement or substitution products, labor costs, product installation or removal costs, or loss of profit. In any and all events, manufacturer's liability shall not exceed the purchase price of the product and/or accessories.

### Ordering Spare Parts

Spare parts can be ordered from your local distributor. Always refer to the pump model to avoid error.

### Other FTI Products

See our full product range at [www.finishthompson.com](http://www.finishthompson.com).

## Part Number Explanation

DB3/4/5 (1" FNPT x 1/2" MNPT) Base Model	
Part Number Configuration	
Polypropylene Models	
Pump End	Wet End
DB3P, DB4P, DB5P	DB3PW, DB4PW, DB5PW
PVDF Models	
DB3V, DB4V, DB5V	DB3VW, DB4VW, DB5VW

Component ▼	Base ▼		Alternative ▼	Code ▼
Bushing	Carbon	<i>or</i>	PTFE	<b>T</b>
			Alumina Ceramic	<b>R</b>
O-ring	FKM	<i>or</i>	EPDM	<b>E</b>
Connection	NPT	<i>or</i>	BSP	<b>B</b>
Motor Adapter	IEC 56/B14 (std for DB3)	<i>or</i>	IEC 63/B14 (std for DB4 & DB5)	<b>64</b>
Motor	Not Standard	<i>or</i>	1/8 Hp (.09 kW), 115V, 1 Ph, 60 Hz, IEC 56 B14 frame, TEFC, CSA, CE	<b>M612</b>
			1/8 Hp (.09 kW), 220V, 1 Ph, 50/60 Hz, IEC 56 B14 frame, TEFC, CE	<b>M614</b>
			1/4 Hp (.19 kW), 115V, 1 Ph, 60 Hz, IEC 63 B14 frame, TEFC, CSA, CE	<b>M613</b>
			1/4 Hp (.19 kW), 220V, 1 Ph, 50/60 Hz, IEC 56 B14 frame, TEFC, CE	<b>M615</b>

1. Example: Select base model, DB3V or DB4P.
2. If standard components are not suitable, enter symbol(s) of alternative components in any order. For example, in part number **DB3V-E-T-M612** - the pump is a DB3 PVDF with EPDM housing O-ring , PTFE bushing and 1/8 Hp 115V motor. In part number, **DB4P-R-B-M615**, the pump is a DB4 polypro with ceramic bushing, BSP threaded ports and 1/4 Hp, 220V, 50/60 Hz motor.
3. There is a price adder for a ceramic bushing option.

**NOTE:** For existing pumps in the field, the model number appears on the label located on the top of the motor adapter. Compare the model number on the pump to the chart above to determine exactly what components the pump contains. Should you have questions, feel free to contact Finish Thompson Inc.

# DB3-4-5 Spare Parts Drawing

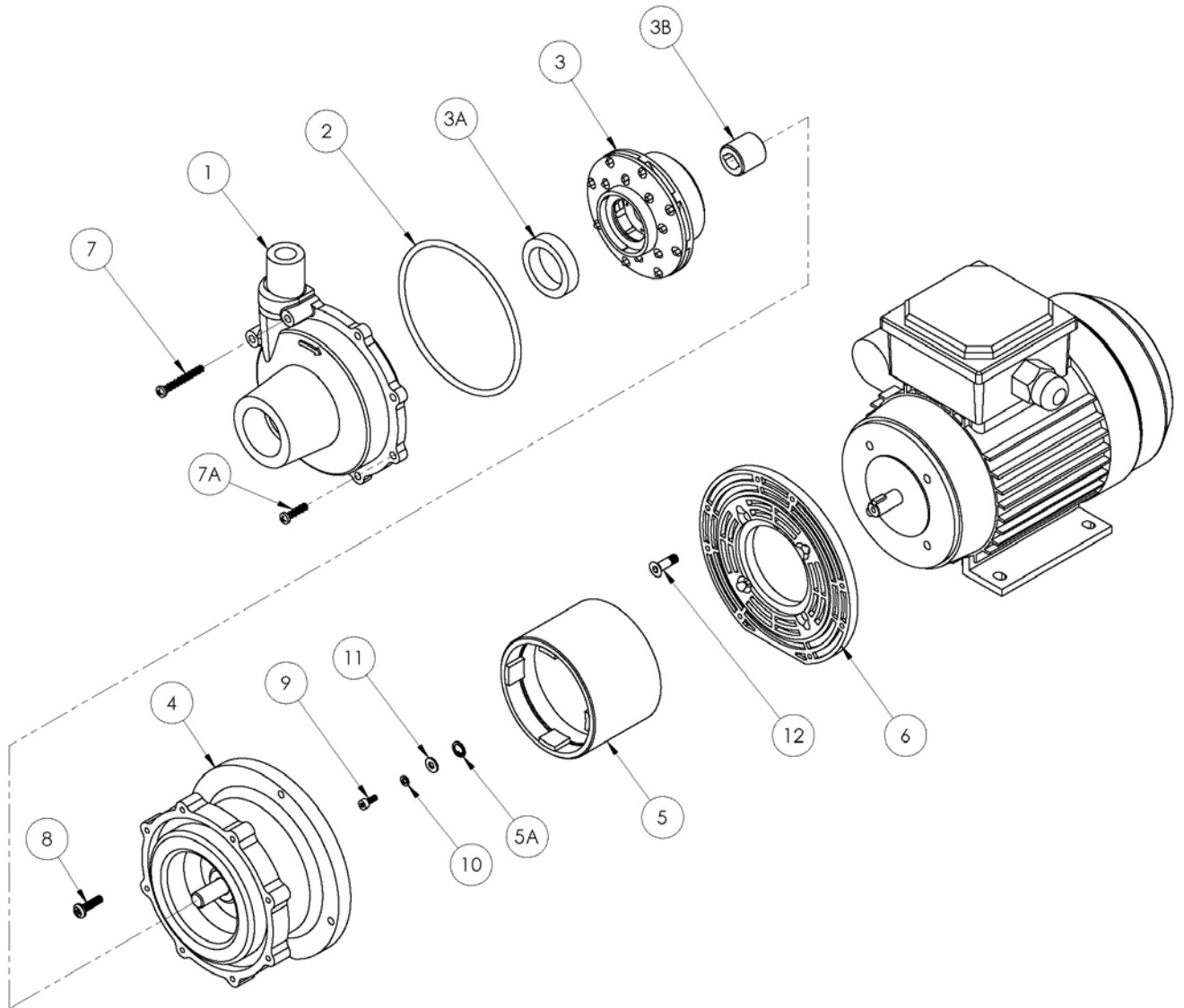

## DB3/4/5 SPARE PARTS LIST

Item No.	Qty.	Description	PP Part No.	PVDF Part No.	
1	1	<b>Impeller Housing with Thrust Ring</b>			
		NPT Thread	A102865-1	A102865-3	
		BSP thread	A102865-2	A102865-4	
2	1	<b>Housing O-ring</b>			
		EPDM	J103571		
		FKM	J103572		
3	1	<b>Impeller Assemblies</b>			
		DB3 Impeller Assembly with Thrust Ring, Ø2.30"	Carbon Bushing	107122-4	107122-5
			PTFE Bushing	107122-10	107122-11
			Ceramic Bushing	107122-16	107122-17
		DB4 Impeller Assembly with Thrust Ring, Ø2.68"	Carbon Bushing	107122-2	107122-3
			PTFE Bushing	107122-8	107122-9
			Ceramic Bushing	107122-14	107122-15
		DB5 Impeller Assembly with Thrust Ring, Ø3.00"	Carbon Bushing	107122	107122-1
			PTFE Bushing	107122-6	107122-7
Ceramic Bushing	107122-12		107122-13		
3A	1	<b>Impeller Thrust Ring</b>	M102141		
3B	1	<b>Impeller Bushings</b>			
		Carbon	J102387		
		PTFE	J102790		
		Ceramic	J103617		
4	1	Motor Adapter/Barrier w/ Ceramic Shaft & Ring	106700	106700-1	
5	1	<b>Outer Drive Magnet Assembly with Retaining Ring</b>			
		56 Frame	107131-1		
		63 Frame	107131		
5A	1	<b>Retaining Ring Only</b>			
		56 Frame	107124		
		63 Frame	106310		
6	1	Motor Adapter Flange	106701	106701-1	
7	6	Housing Screw	J101020		
7A	2	Discharge Housing Screw - Long	107570		
8	4	Motor Adapter/Barrier Screw	J101020		
9	1	<b>Drive Bolt</b>			
		56 Frame	107142		
		63 Frame	106314		
10	1	<b>Drive Lockwasher</b>			
		56 Frame	107141		
		63 Frame	106322		
11	1	<b>Drive Flatwasher</b>			
		56 Frame	107125		
		63 Frame	106318		
12	4	Motor Adapter Flange Bolt	107140		



### FINISH THOMPSON INC.

921 Greengarden Road • Erie, PA 16501-1591 U.S.A.  
 Ph 814-455-4478 • Fax 814-455-8518  
 Email [fti@finishthompson.com](mailto:fti@finishthompson.com) • [www.finishthompson.com](http://www.finishthompson.com)

P/N 107599  
 Lit ID FT10-1123